

# Automatic Recording Apparatus for Thermal Stability Determinations

KURT R. FISCH

Nonmetallic Materials Laboratory, Materials Central, Wright Air Development Division, Wright-Patterson Air Force Base, Ohio

FRANK D. VERDERAME

Pitman-Dunn Laboratories, Frankford Arsenal, Philadelphia, Pa.

THE CURRENT emphasis on materials for high temperature application stimulated a search for a reliable evaluation technique of their thermal stability, or resistance to thermal breakdown. In view of the many possible mechanisms of thermal decomposition, it does not seem possible to design a technique which will measure decomposition rates in terms of the reaction rate constant,  $k$ , for all classes of compounds or even within one class. It was therefore necessary to develop empirical tests which will give some indication of the relative resistance of compounds to thermal breakdown. Several empirical test methods are now in use. They include pyrolysis of the test fluid in a cell under 1 atm. of nitrogen (10); in a sealed cylinder incorporating a pressure gage (13); in a sealed glass tube (1, 7, 9, 11); and in an open tared vessel under a stream of nitrogen (3). The criteria of fluid decomposition involve measurement of changes in the physical properties of the fluids, such as viscosity, weight loss, or the generation of pressure.

Tests involving comparison of loss of weight and change in viscosity at a single temperature have inherent shortcomings. Thus, the test temperature and time of exposure may be inadequate to differentiate between compounds of similar structure; often, the changes in viscosity are masked by compensatory viscosities of reaction products and sometimes the products formed may be nonvolatile. As a consequence, reliable interpretation of data is almost impossible and distinguishing among the relative values of thermal stability data is doubtful at best. Tests which are conducted in an uncontrolled atmosphere (8) complicate the problem further by permitting oxidation and hydrolysis to occur simultaneously.

The Smith and Menzies isoteniscope (16) has recently been adopted as a tool for measuring thermal stability. Early reports by Ballentine (2), and Blake, Edwards, and Hamman (3), who used a modified version of the isoteniscope for determination of thermal decomposition rates, describe a technique for measuring a "threshold" decomposition temperature of a fluid by determining its vapor pressure at uniformly increasing temperatures and then plotting  $\log p$  vs.  $1/T$ . Because of uncertainties often encountered in selecting the point of departure from a straight line caused by decomposition products, the procedure was later revised by Blake and others (4). First, the equilibrium vapor pressure was measured; then the temperature was raised approximately 75° to 100° C. The rate of pressure rise at constant temperature  $(\Delta P/\Delta t)_T$  due to decomposition was measured at this temperature, followed by similar determinations at several successively lower temperatures. The temperature at which  $(\Delta P/\Delta t)_T$  was equal to 0.014 mm. of Hg per second was defined as the decomposition temperature,  $T_d$ . This corresponded to a pressure rise of 500 mm. of Hg within 10 hours, which was an arbitrary criterion based upon what was considered acceptable under actual service conditions. The revised method which was evaluated at this laboratory was found to give a reproducibility of  $T_d$  values within 5° C.

The reliability of the method and the nature of the data obtained caused considerable interest in isoteniscope techniques by laboratories engaged in the development of high-

temperature fluids (6, 12, 14, 15). The principal objectionable feature of the method was that it was tedious and time-consuming, requiring the continuous attention of the operator.

To overcome this drawback, this test method was made automatic by the introduction of a servomechanism. Pressure increases are detected by means of a Bodenstein quartz spiral manometer (Figure 1). A mirror is attached to the top of the gage spiral. A light source and lens arrangement permit detection of pressure changes by means of two photoelectric cells. The amplified current activates a solenoid, admitting nitrogen into the system. When the light beam reaches the second cell, the solenoid is deactivated, closing the nitrogen supply. The distance between cells corresponds to a definite pressure increment. A recording timer is placed in the circuit measuring the interval between cell activations. All power lines are automatically disconnected, when the total pressure within the system exceeds a preset amount. With this arrangement, it is possible to determine thermal decomposition rates unattended. This eliminates the drudgery of constant attention and results in considerable saving in time and effort.

## APPARATUS

The schematic layout of the automatic thermal decomposition apparatus is shown in Figure 2. The apparatus consists of an all-glass vacuum system which can be evacuated to 5 to 10 microns. Arrangement of the taps permits isolation of various sections of this system.

**Constant Temperature Bath.** The salt bath consists of an eutectic mixture (3) of 27.3%  $\text{LiNO}_3$ , 18.2%  $\text{NaNO}_3$ , and 54.4%  $\text{KNO}_3$  (melting point approximately 250° F.) contained in a round-bottomed, cylindrical borosilicate glass vessel with insulated side walls. The bath is constantly maintained at a temperature above its melting point by a 250-watt, 500-ml. quartz heating mantle. The bath rests

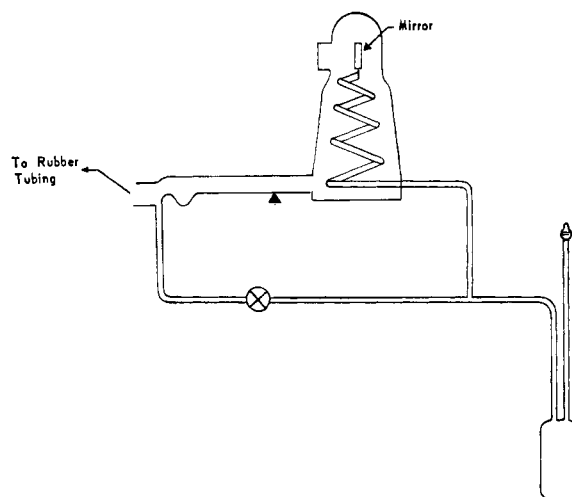

Figure 1. Bodenstein gage and test cell

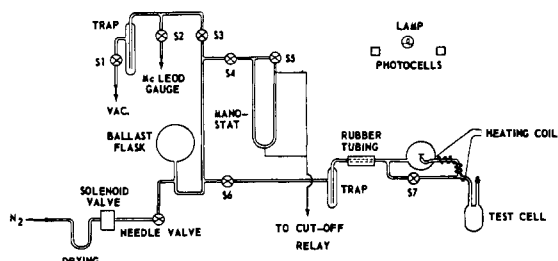

Figure 2. Automatic thermal decomposition apparatus

on a steel plate which may be raised or lowered on a sturdy ring stand and is positioned directly underneath the mounted test cell so that the latter's position need not be changed. Raising of the bath into position is facilitated by the use of a hydraulic lift.

The temperature of the bath is regulated by a sensing element having a range of 0° to 1000° F. Heat is supplied by a 500-watt, 120-volt control "hairpin" immersion heater. With this arrangement the temperature can be controlled to  $\pm 0.1^\circ$  F. up to approximately 900° F. A National Bureau of Standards calibrated platinum resistance thermometer, using a portable precision Wheatstone bridge and galvanometer, is used for temperature determinations. Quick lowering of the bath temperature can be effected by temporary immersion of a small coil of copper tubing  $\frac{3}{16}$  inch in outside diameter, through which tap water is circulated.

**Bodenstein Gage and Test Cell.** The Bodenstein gage (5) shown in Figure 1 is made of quartz (American Fuzed Quartz Co. No. T/SI/450G) and is connected to the borosilicate glass test cell by means of a graded seal. The hollow spiral of the gage can withstand a pressure differential of about 3 atm. The fabrication technique is described by Vaughan (17).

The test cell and Bodenstein gage assembly are connected to the vacuum and pressure measuring systems as shown in Figure 2. Thus, with stopcock 7 closed, any pressure change inside the test cell causes the mirror to be deflected because of winding or unwinding of the hollow quartz spiral produced by the pressure difference between the inside and outside of the coil. The reflected light image cast onto the scale and photoelectric cells is displaced by an amount proportional to the displacement of the mirror. The Bodenstein gage and the glass tubing joining the gage with the

test cell are externally heated by means of high-resistance, asbestos-covered wire to prevent clogging of the spiral with decomposition products and condensates. Correlation between temperature inside the gage and applied voltage can easily be established by inserting a thermocouple into the gage. Caution should be exercised, since the mirror may become oxidized from prolonged heating in air. It has been found expedient to keep the gage temperature approximately 20° C. above the bath temperature. The gage and test cell are mounted in a fixed position by means of two spring grip microclamps so that the optical alignment of the light source, mirror, lens, and photoelectric cells remains undisturbed at all times. The trap prevents any liquid from being sucked into the gage body.

The test cell (Figure 1) has a capacity of  $6.98 \pm 0.02$  ml. It is filled and cleaned through the spherical joint. It is convenient to graduate this cell in order to read volume accurately.

**Optical and Electronic Equipment.** The light source, located above the photocells, is a focusing galvanometer lamp. The face of the lamp is masked, permitting passage of a vertical light beam 3.8 mm. wide. This beam of light passes through a 1-meter focal length lens located in front of the mirror atop the quartz spiral, and the reflected image is focused on the millimeter scale and photoelectric cells. Once set up in this manner, the sensitivity of the gage can be measured in a dry run using nitrogen on the cell side, and is defined as the pressure in millimeters of mercury necessary to cause a horizontal displacement of 1 mm. of the light image on the scale at a distance of 1 meter. The gage used in this work had a sensitivity of 1.4 mm. of Hg per mm. (It is desirable to use a gage having a sensitivity of not more than 2.0 mm. of Hg per mm.)

The photoelectric cells are two 1N85 transistors, mounted on the millimeter scale in such fashion as to permit a quick change in their respective positions. The distance traversed by the light image is determined by measuring the distance one edge of the light beam travels between cell actuations. The sensitivity of the cells is adjusted by means of the two variable resistors in the control box. The left-hand cell (No. 1) closes the solenoid, shutting off the passage of nitrogen into the gas measuring section, whereas the solenoid is opened by the activation of cell 2, admitting nitrogen until the light beam returns to cell 1. The circuit diagram is shown in Figure 3.

The solenoid is leakproof to 1 micron. The nitrogen inlet flow is regulated manually by a high-vacuum needle valve.

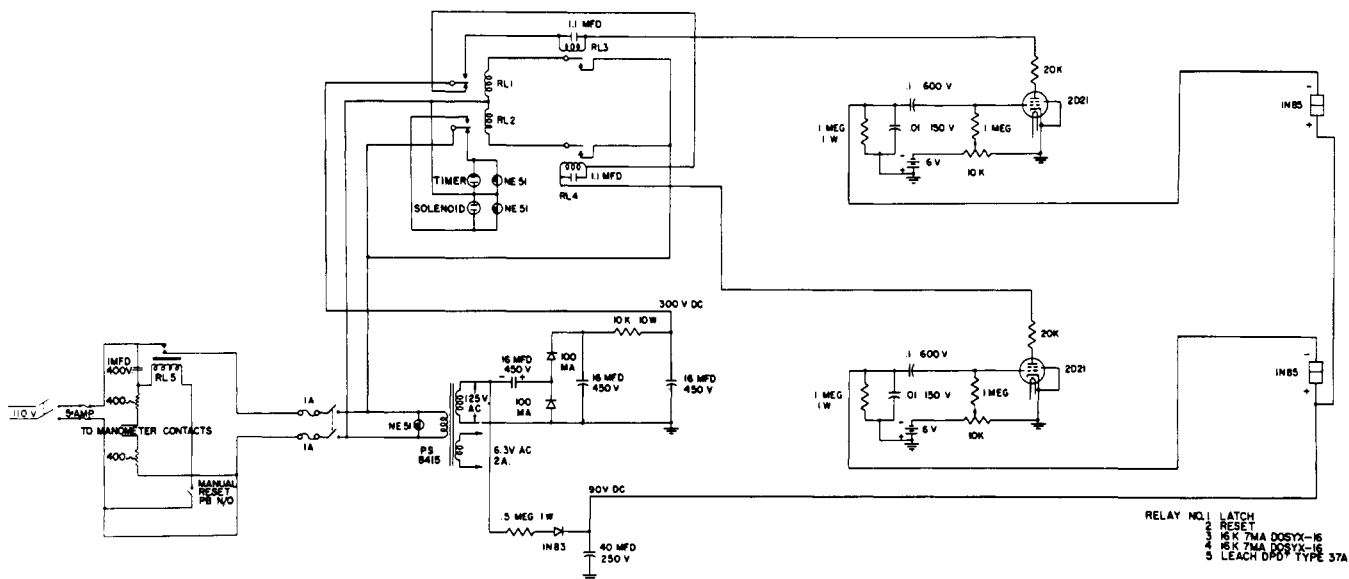

Figure 3. Wiring diagram for automatic thermal decomposition apparatus

**Timer.** A recording milliammeter is used as the timer. Adjustments were made to give a chart speed of  $\frac{3}{4}$  inch per minute. A deflection of the needle occurs each time a photocell is actuated and the time between peaks is read to within 3 seconds and estimated to 1 second.

The closed-end manometer is used as a manostat in that wire (Kovar) contacts are sealed in as indicated in Figure 2, and are connected to the cutoff relay box as shown in Figure 3. The contacts are set so that when a total pressure of approximately 700 mm. of Hg is built up, all 110-volt lines which are plugged into the safety relay box are disconnected and can only be reset manually. In addition to terminating the test automatically, this arrangement also prevents erratic results because of temporary power breaks, leaks, and similar interruptions.

#### OPERATION OF EQUIPMENT

The following operations are performed while waiting for the bath to attain constant temperature.

1. The test cell is cleaned with appropriate solvent, dried, placed in its prealigned position, and evacuated by means of a water aspirator, while heating it with the resistance wire to complete dryness.

2. Three milliliters of test fluid are injected through the spherical joint. The lamp, photocells, lens, and gage are adjusted so that a sharp light image is produced on cell 2. The nitrogen inlet valve remains closed.

3. With stopcock 7 open, the system is completely evacuated. The nitrogen inlet valve is opened and the entire system flushed five times with 100-mm. portions of nitrogen. With stopcock 7 closed, and stopcock 3 and the nitrogen inlet valve slightly open, the light image is made to move slowly between cells 1 and 2 by alternately admitting nitrogen, then allowing it to evacuate. In this manner, adjustments in the proper operation and sensitivity of the cells can be made by adjusting the variable resistors in the control box. The distance traversed by the image is measured on the scale by using one edge of the light image as reference point between cell actuations.

4. With the nitrogen valve closed and stopcock 7 opened, the entire system is completely evacuated to about 7 microns. Stopcock 3 is closed and the system is checked for leaks by noting any pressure rise after 10 to 15 minutes.

5. When no pressure rise is discernible, stopcock 3 is opened and the heating coil of the gage is turned on to raise the temperature about 20° C. above bath temperature.

The test cell is degassed by heating gently with a Bunsen burner. The gage should be hot before degassing.

6. When the pressure is at a minimum again and the bath temperature becomes constant, stopcocks 3, 1, and 7 (in that order) are closed and the pump is shut off. The nitrogen inlet valve is opened  $\frac{1}{4}$  turn, causing the light to move from cell 2 toward cell 1, admitting a pressure of nitrogen equivalent to the distance between cells.

After attaining constant temperature, the bath is raised to submerge the test cell completely.

The vapor pressure of the fluid at this temperature can be estimated when desired in the following manner: When the cell is first immersed in the salt bath, the rapid increase of pressure causes rapid cell activations until the pressure approaches equilibrium and the rate of travel of the light image becomes much slower. Since the test is started with the image at cell 1, the pressure increment times the number of cell activations, plus the distance from cell 1 at which the reference edge of the light image comes to rest, multiplied by the sensitivity of the gage gives a good approximation of the vapor pressure. The beginning and end of these determinations are marked on the timer chart. The determination then becomes automatic.

At the end of the test, the bath is lowered and the temperature decreased 15° to 25° C., by temporary immersion of the copper cooling coil. The entire system is re-evacuated prior to measurements at 25° C.

At the end of the test, the bath is lowered while the gage heating coil is left on until the test cell has attained ambient temperature. Stopcocks 7 and 3 are opened and the entire system is evacuated. This is followed by admission of nitrogen to atmospheric pressure.

#### RESULTS

Thermal decomposition rates of several compounds were determined and the data are presented in Tables I to IV. The pressure increment,  $\Delta p_{\text{calcd.}}$ , is the product of the predetermined distance between cells,  $\Delta d$ , and the sensitivity

Table I. Thermal Decomposition Rate of Bis(2-ethylhexyl) Sebacate

Cell 2 Acti- vations	Observed Pressure Increment, $\Delta p_{\text{obsd.}}$ Mm. Hg	Recorded Time Interval, $\Delta t$ , Sec.	Rate of Pressure Increase, $\Delta P/\Delta t$ , Mm. Hg/Sec.	
			Observed	Automatic
Temperature. 299.7° ± 0.1° C. $p_{\text{calcd.}}$ 20.5 mm.				
1	20.3	390	0.052	0.052
2	22.0	425	0.052	0.048
3	21.0	435	0.048	0.047
4	22.0	480	0.046	0.042
5	19.7	375	0.052	0.054
6	19.8	390	0.051	0.052
7	20.2	375	0.054	0.054
8	19.7	420	0.047	0.048
9	19.5	417	0.047	0.049
Av.	20.5			
Temperature. 231.2° ± 0.1° C. $p_{\text{calcd.}}$ 21.0 mm.				
1	21.8	1870	0.0170	0.0112
2	21.1	1615	0.0131	0.0130
3	21.5	2405	0.0089	0.0087
4	20.8	1475	0.0141	0.0142
Av.	21.3			

Table II. Thermal Decomposition Rates of Tetra(2-ethylhexyl) Silicate

Cell 2 Activations	Observed Pressure Increment $\Delta p_{\text{obsd.}}$ Mm. Hg	Recorded Time Interval, $\Delta t$ , Sec.	Rate of Pressure Increase, $\Delta P/\Delta t$ , Mm. Hg/Sec.	
			Observed	Automatic
Temperature. 339.4° ± 0.1° C. $p_{\text{calcd.}}$ 18.2 mm.				
1	20.1	34	0.3720	0.337
2	19.3	81	0.2373	0.223
3	18.9	93	0.2032	0.196
4	18.8	98	0.1918	0.186
5	18.2	108	0.1685	0.168
6	18.0	123	0.1463	0.148
7	18.1	120	0.1508	0.152
8	18.1	141	0.1284	0.129
9	18.5	132	0.1402	0.138
10	17.0	130	0.1308	0.140
11	17.6	130	0.1354	0.140
12	17.8	130	0.1369	0.140
13	17.4	135	0.1289	0.135
Av.	18.3			
Temperature. 319.8° ± 0.1° C. $p_{\text{calcd.}}$ 19.2 mm.				
1	19.5	375	0.0520	0.052
2	19.2	363	0.0530	0.055
3	20.6	384	0.0536	0.051
4	18.0	380	0.0474	0.052
5	17.5	408	0.0430	0.048
6	18.5	576	0.0492	0.052
7	19.5	447	0.0436	0.044
8	16.6	453	0.0366	0.043
9	17.9	450	0.0398	0.043
10	18.3	456	0.0401	0.043
Av.	18.6			

Table III. Comparison of Automatically Recorded and Observed Rates

Compound	Temp., ° C.	$\Delta p/\Delta t$ , Mm. Hg/Sec.		Deviation	
		Observed	Automatic	Mm. Hg/sec.	%
Bis( $\beta$ -phenylpropyl) azelate	336.2	0.625	0.622	0.003	0.5
Bis( $\beta$ -phenylpropyl) azelate	301.9	0.037	0.038	0.001	2.7
Tricresyl phosphate	373.2	0.020	0.021	0.001	5.0
Tricresyl phosphate	359.5	0.014	0.014	0.000	0.0
Tetra(2-ethylhexyl) silicate	339.4	0.135	0.140	0.003	3.7
Tetra(2-ethylhexyl) silicate	319.8	0.040	0.043	0.003	7.5
Bis(2-ethylhexyl) sebacate	299.7	0.047	0.048	0.001	2.1
Bis(2-ethylhexyl) sebacate	281.2	0.014	0.014	0.000	0.0
Tetra( <i>n</i> -hexyl) silicate	346.5	0.020	0.016	0.004	20.0
Tetra( <i>n</i> -hexyl) silicate	337.5	0.015	0.015	0.000	0.0
Tri( <i>n</i> -lauryl)silicon fluoride	358.9	0.039	0.039	0.000	0.0
Tri( <i>n</i> -lauryl)silicon fluoride	347.6	0.021	0.021	0.000	0.0
				Av.	3.6

of the gage (1.4 mm. of Hg per mm.). Each  $\Delta p_{\text{calcd.}}$  is divided by the time increment  $\Delta t$  to give the decomposition rate. The recorded pressure increments of nitrogen admitted by the activation of cell 2 were simultaneously read on the manometer and these data appear as  $\Delta p_{\text{obsd.}}$  Tables I and II contain comparisons between observed and automatic readings. The data show excellent agreement. Similar data for several other compounds are summarized in Table III. The reproducibility of the mean deviation between observed and automatic rates expressed as a fraction of the mean is 3.6%.

The  $\Delta p/\Delta t$  values for each fluid tested were plotted as  $\log \Delta p/\Delta t$  vs.  $1/T$ , and the decomposition temperatures—i.e., the temperatures at which  $\Delta p/\Delta t = 0.014$  mm. of Hg per second—were compared wherever possible with data obtained on the isoteniscope. These data are in Table IV. The data indicate that there is reasonable agreement between the two methods. The data in Tables I and II are typical for this method, in that there is a gradual leveling of the pressure rate. In cases where data are found to drift without reaching a steady value, the mean of the last three or four readings is selected. The slight differences in  $T_d$  values in Table IV may be attributed to the fact that different amounts of test fluids were used and that the free volumes above the liquid were different in the two methods.

The apparatus described is essentially a modification of that used by earlier workers to obtain rate of change of pressure data. Although some initial effort in setting up is involved, the saving in time is considerable. Whereas the isoteniscope requires constant attention throughout the

test period, the incorporation of the automatic feature reduces the working time considerably. A typical run requires about 1 hour of work to get a determination started, about 20 minutes to cool the bath to a lower temperature, and about 10 minutes to disassemble the apparatus.

#### ACKNOWLEDGMENT

The assistance of J.H. Daniels and James Katarynick, Special Devices, RAD, Frankford Arsenal, in constructing the electronic control unit is gratefully acknowledged.

The authors thank the Ordnance Corps., Department of the Army, for permission to publish this paper.

#### LITERATURE CITED

- (1) Adams, H.W., Baum, G., *WADC Tech. Rept.* 57-168 (March 1958).
- (2) Ballentine, O.M., *Ibid.*, 54-417 (March 1955).
- (3) Blake, E.S., Edwards, J.W., Hamman, W.C., *Ibid.*, 54-532 (March 1955).
- (4) Blake, E.S., Edwards, J.W., Hamman, W.C., Reichart, T., *Ibid.*, 54-532, Part III (April 1957).
- (5) Bodenstern, Max, Dux, Walter, *J. Phys. Chem.* 85, 297 (1913).
- (6) Chappelow, C.C., Clark, R.N., *WADC Tech. Rept.* 58-84 (January 1958).
- (7) Cramer, H.R., Wasson, R.L., Sawyer, A.W., *Ibid.*, 57-581 (March 1958).
- (8) Gilman, Henry, Gorsich, R.D., *Ibid.*, 53-426, Part I (April 1954).
- (9) Grafstein, Daniel, Cohen, M.S., *Ibid.*, 57-45, Part I (January 1958).
- (10) Klaus, E.E., Fenske, M.R., *Ibid.*, 56-224 (September 1956).
- (11) Peeler, R.L., Kovacich, S.A., *Ibid.*, 57-119 (July 1957).
- (12) Raley, C.F., *Ibid.*, 53-33, Part III (1955).
- (13) Schiefer, H.M., *Ibid.*, 55-89, Part II, (July 1956).
- (14) Schmidt, J.E., Krimmel, J.A., Hobaugh, J.R., *Ibid.*, 56-207 (October 1956).
- (15) Schmidt, J.E., Krimmel, J.A., Farrel, T., Jr., *Ibid.*, 56-207, Part II (April 1958).
- (16) Smith, A., Menzies, A.W.C., *J. Am. Chem. Soc.* 32, 891, 907, 1412 (1910).
- (17) Vaughan, W.E., *Rev. Sci. Instr.* 18, 792 (1947).

RECEIVED for review March 8, 1960. Accepted July 27, 1960. Work done at Pitman-Dunn Laboratories, Frankford Arsenal.

Table IV. Thermal Decomposition Temperatures by Isoteniscope and Automatic Methods

Compound	$T_d$ , ° C.			
	Automatic		Isoteniscope	
Tetra( <i>n</i> -hexyl) silicate	339	336	348	348
Tri( <i>n</i> -Lauryl)silicon fluoride	327	337	340	336
Tetra(2-ethylhexyl) silicate	303	304	309	311
Bis(2-ethylhexyl) sebacate	281	283	277	288